

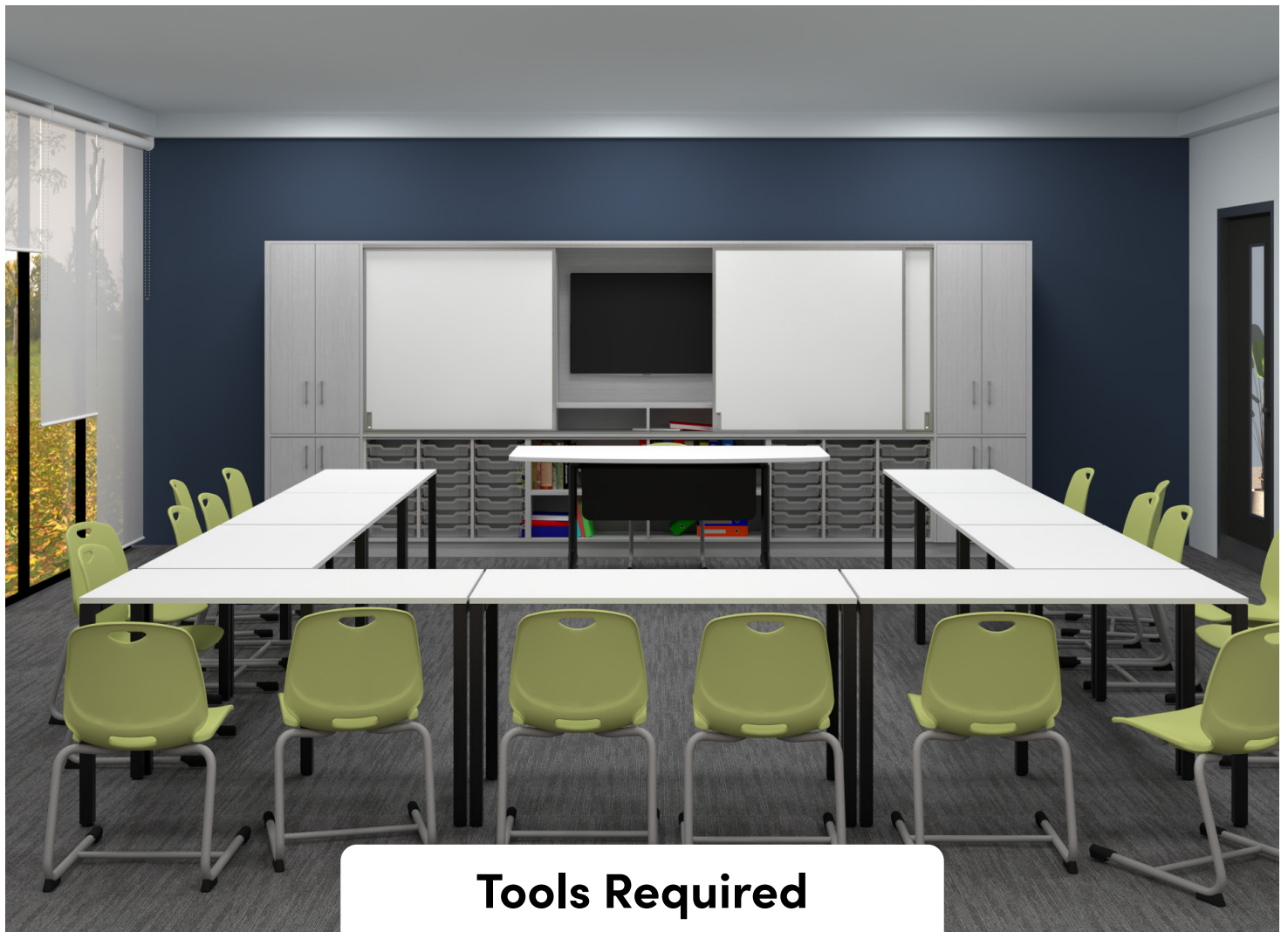

# AVERO DESK **ASSEMBLY GUIDE**





## Tools Required



Battery Drill



Phillips Driver Tip

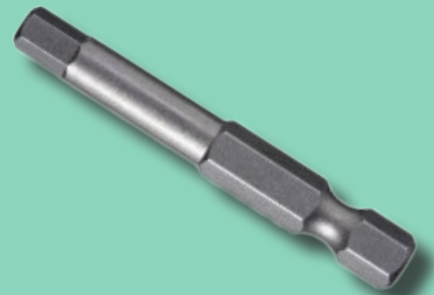

4mm Hex Bit

**Accent**  
workspace furniture solutions

# CORNER WORKSTATION

## PARTS LIST

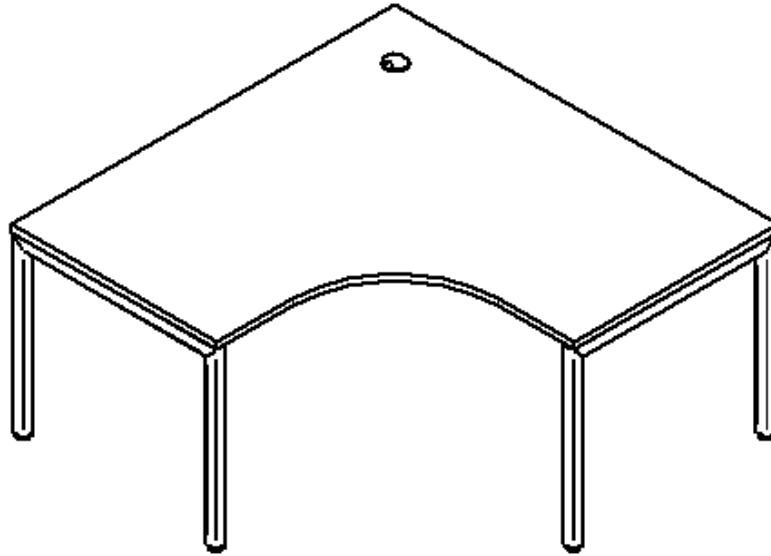

NO.	NAME	QUANTITY	IMAGE
1	Desk Top	1pc	
2	Leg Frame	3pcs	
3	Fixed Beam	1pc	
4	Extendable Beam	1pc	
5	Cable Entry	1pc	
6	Wood Screw	18pcs	
7	CSK Bolt	6pcs	
8	Flat Head Bolt	6pcs	

# CORNER WORKSTATION

## ASSEMBLY INSTRUCTION

### STEP 1

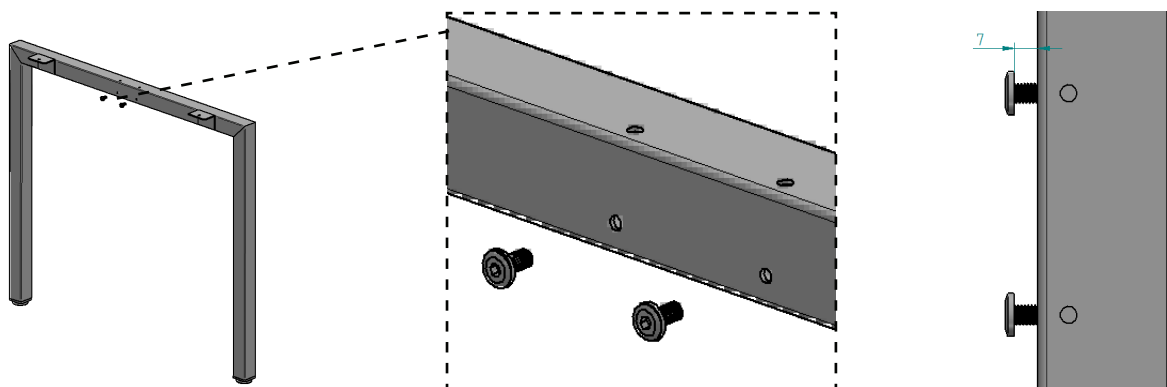

Install flat head bolts to the side of the leg. Note: Ensure the flat head bolt is installed with the head protruding approximately 7mm from the surface. This spacing is necessary for the next step.

### STEP 2

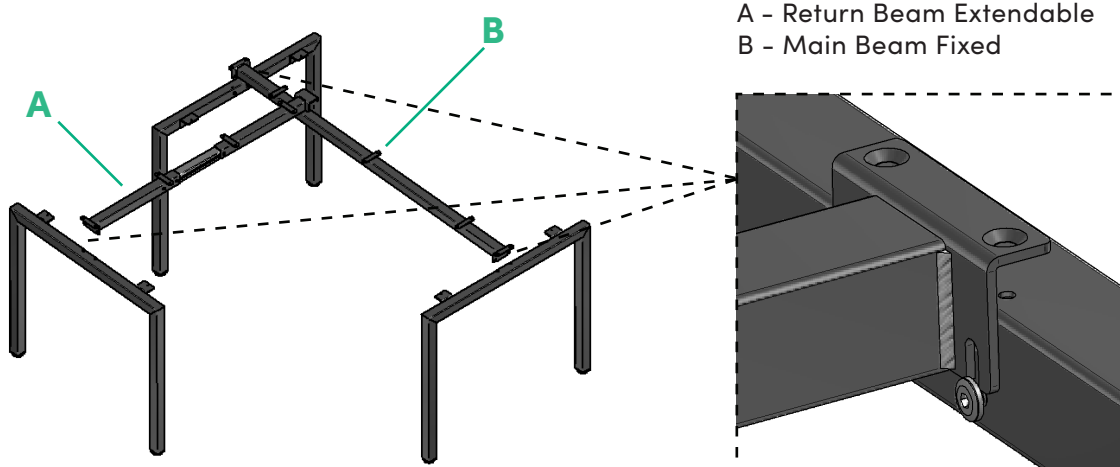

A - Return Beam Extendable  
B - Main Beam Fixed

Attach the beam to the legs.

### STEP 3

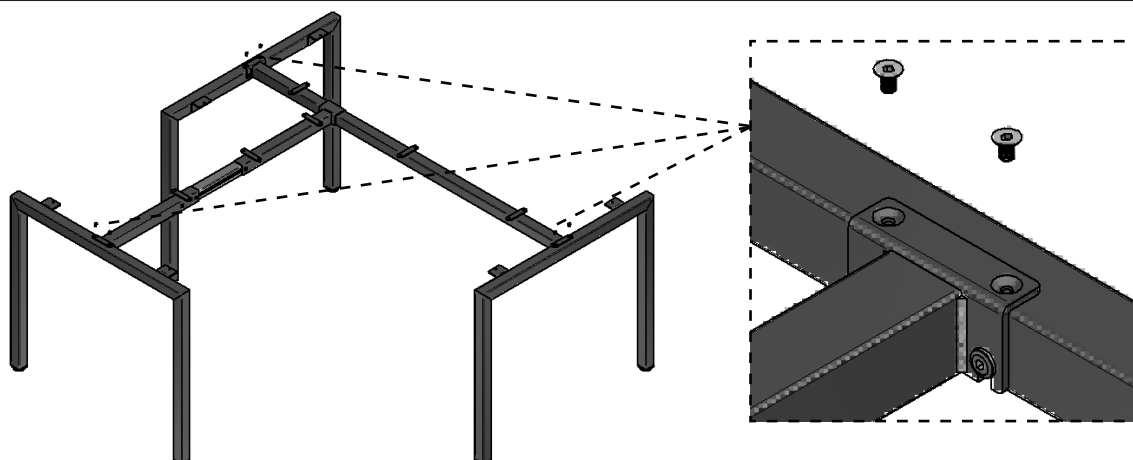

Attach the beam onto the leg frame, tighten flat head bolts on the side of the leg frame.  
*Do not overtighten – excessive force may strip threads or damage component.*

# CORNER WORKSTATION

## ASSEMBLY INSTRUCTION

### STEP 4

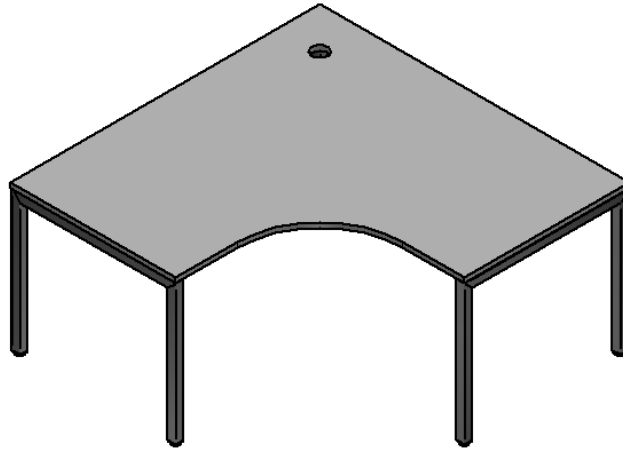

Place desktops onto the frame. Attach the frame to the desktop.

### STEP 5

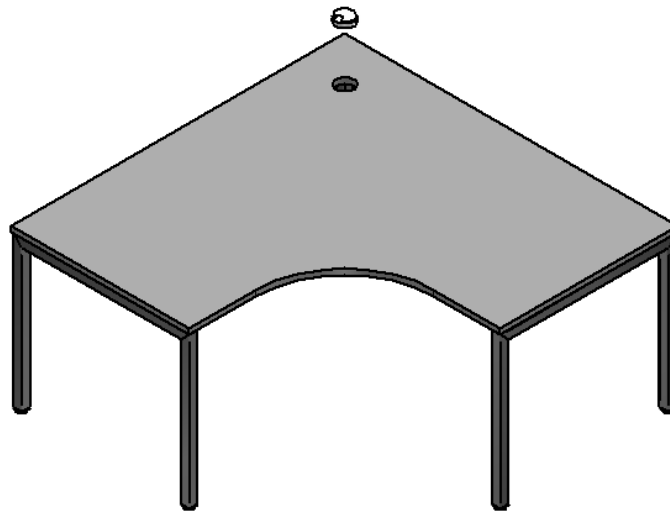

Install cable port.

### STEP 6

